

# LHC Collimation PHASE II

## 9<sup>th</sup> Design Meeting - 05/09/2008

*Present:* Gonzalo Arnau Izquierdo, Arnaud Pierre Bouzoud, Roger Perret, Samuli Heikkinen, Gilles Favre, Ahmed Cherif, Wilhelmus Vollenberg, Luisella Lari, Oliver Aberle, Sebastien Perrolaz, Jeff Smith (SLAC), Alessandro Bertarelli (chairman), Alessandro Dallocchio (scientific secretary).

### 1. Outcome of the visit to PLANSEE. (A. Bertarelli - G. Arnau Izquierdo)

*Bertarelli* opened the meeting with a brief summary of the visit to PLANSEE:

- PLANSEE confirmed the feasibility of the Molybdenum back-stiffener with the present design (some details should be better defined).
- Production of bended Mo pipes seems really difficult but should be studied more in detail; PLANSEE proposed other materials.
- PLANSEE is interested in a wide-range collaboration with CERN for the Collimation Phase II Project including the development of Cu-Diamond components.

*Arnau Izquierdo* held a [presentation](#) giving more details about the design aspects discussed with PLANSEE of the various components of the jaw assembly.

#### **Molybdenum back-stiffener**

*Arnau Izquierdo* explained the choice of Molybdenum based on a figure of merit (high thermal conductivity, high Young modulus, low CTE).

Present design foresees the back stiffener to be made up of two long plates reinforced by transversal ribs and connected by screws.

PLANSEE confirmed they can provide long Mo plates (1100 mm) as well as all other components of the stiffener, they are also able to machine all the pieces and to provide screws made up of several materials (possible problems coming from seizing up of screws must be studied). Molybdenum should not give any problems in terms of geometrical stability after thermal cycling (bake-out) and is compliant with UHV specifications.

Finally, PLANSEE believes to be able to produce the complete back-stiffener (10-12 weeks are expected to provide prototypes).

#### **Cooling pipes**

*Arnau Izquierdo* showed different solutions studied for the cooling system focusing on bended pipes embedded in a block of Metal-diamond; this solution is the most promising in terms of UHV requirements and cooling efficiency.

Some considerations about metallurgical compatibility and thermo-physical properties leads to the identification of suitable materials:

- Molybdenum, Tantalum or Niobium pipes embedded in a Cu-Diamond block.
- Zirconium pipes embedded in a Al-Diamond block.

PLANSEE said that is really difficult to bend Molybdenum pipes, Tantalum and Niobium are more promising but an R&D study must be done on this subject.

*Bertarelli* remarked that the other solution (pipes directly machined from a block with welded covers must be investigated more in details especially concerning UHV requirements).

### **Cu-Diamond jaw**

*Arnau Izquierdo* explained that PLANSEE is only interested in developing Cu-Diamond components (no Al-Diamond). At the moment they cannot produce components longer than 600mm but they are interested in a R&D programme in collaboration with CERN.

PLANSEE confirmed their capability of producing Cu-Diamond components with a thick Cu coating (up to 2mm). This is an important detail because allow us to build a Cu-Diamond jaw with the needed length (1200mm), starting from shorter Cu coated blocks EB welded. This option must be carefully evaluated.

As a preliminary estimation, PLANSEE needs 6-10 Months of R&D in order to study the manufacturing of a complete prototype of the jaw assembly (back-stiffener + cooling circuit + jaw).

## **2. Preliminary results of thermo-mechanical analysis. (A. Bertarelli)**

*Bertarelli* showed results of a [preliminary thermo-mechanical analysis](#) performed to assess the thermo-structural behaviour of the jaw assembly in case of nominal steady-state condition (1h beam lifetime at  $0.8e^{10}$  p/s).

- Energy deposition was obtained with FLUKA simulation based on a old design version of the jaw assembly.
- FLUKA results are applied as heat loads on the last version of the design (this hypothesis introduces a certain error in the results).
- Material used for this simulation are Molybdenum for the back stiffener and Copper for the cooling circuit and the jaw.
- Simplified boundary condition are used to simulate the cooling circuit: temperature has been fixed (27°C) on cooling pipes while the convection coefficient and the variation of temperature between inlet and outlet water flow are neglected.

Results based on these simplified hypotheses showed a good geometrical stability of the jaw assembly:

- Maximum temperature found on the jaw is ~46°C (a maximum temperature up to 60°C should be expected with a more detailed simulation).
- Maximum  $\Delta T$  on the back stiffener is  $1\div 2^\circ\text{C}$ .
- Maximum deflection is ~100 $\mu\text{m}$ .

In conclusion, this analysis shows that the design based on back-stiffener + jaw with central regulation system works correctly.

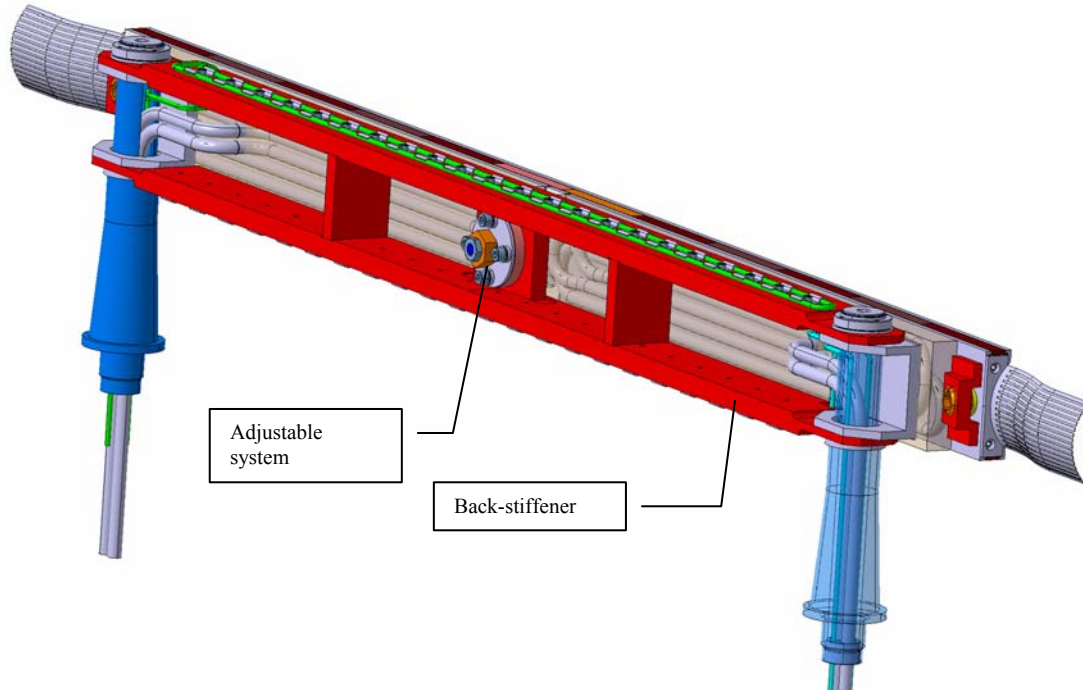
The position of cooling pipes on the back-stiffener could be optimized in order to minimize its thermal deflection. Furthermore, *Bertarelli* showed that links between jaw and stiffener, in addition to the central adjustable system, give worse results.

On the contrary, the central regulation system presently placed at the middle of the block can be shifted toward the hot region of the jaw with the aim of minimize the global thermal deflection. More detailed analysis will be performed.

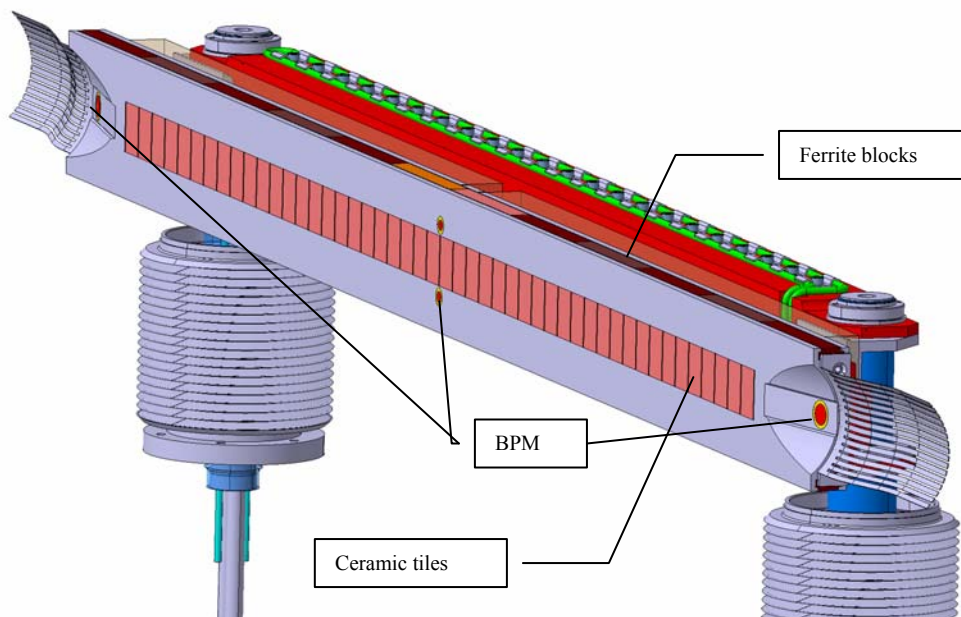
### 3. Follow up of design solution. (A. Bouzoud)

*Perret* explained that he is finalizing the study of the preliminary design of the Phase II actuation system based on linear shaft guiding; production of one prototype will be launched as soon as the plans will be finished.

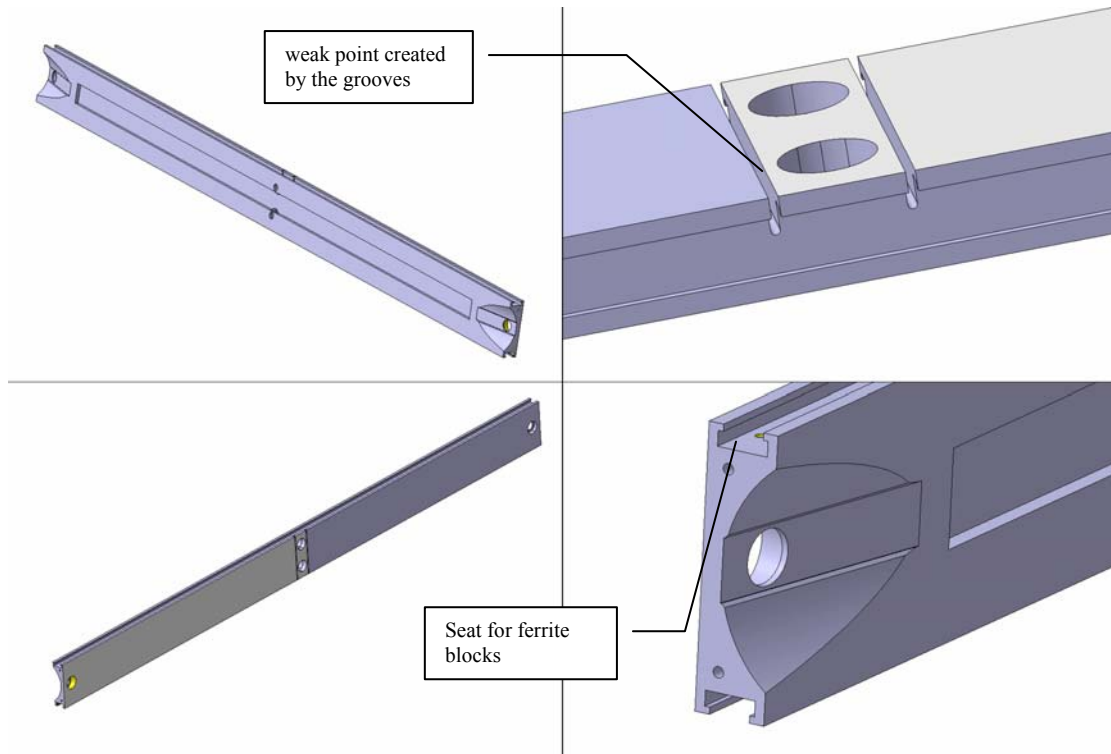
*Bouzoud* made a summary of the present status of the design focusing on the BPM cables that needs some changes in order to allow a correct assembly procedure.



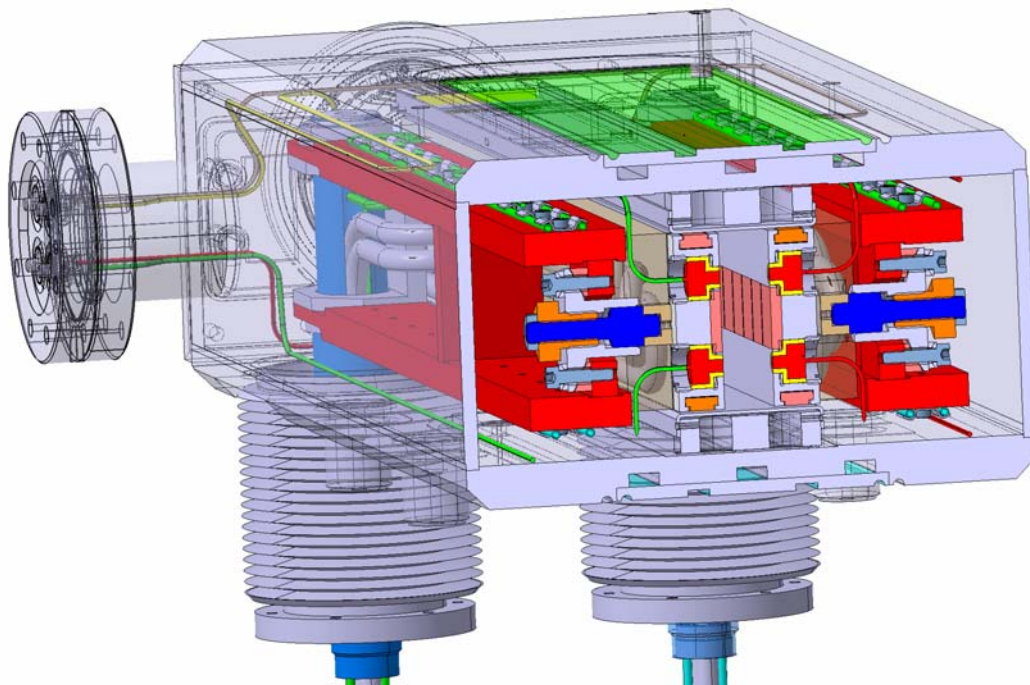
**Figure 1:** Last version of the back-stiffener (red component) made up of two long plate and reinforced by transversal ribs.



**Figure 2:** Last version of the jaw: metallic support with ceramic tiles and integrated BPM.

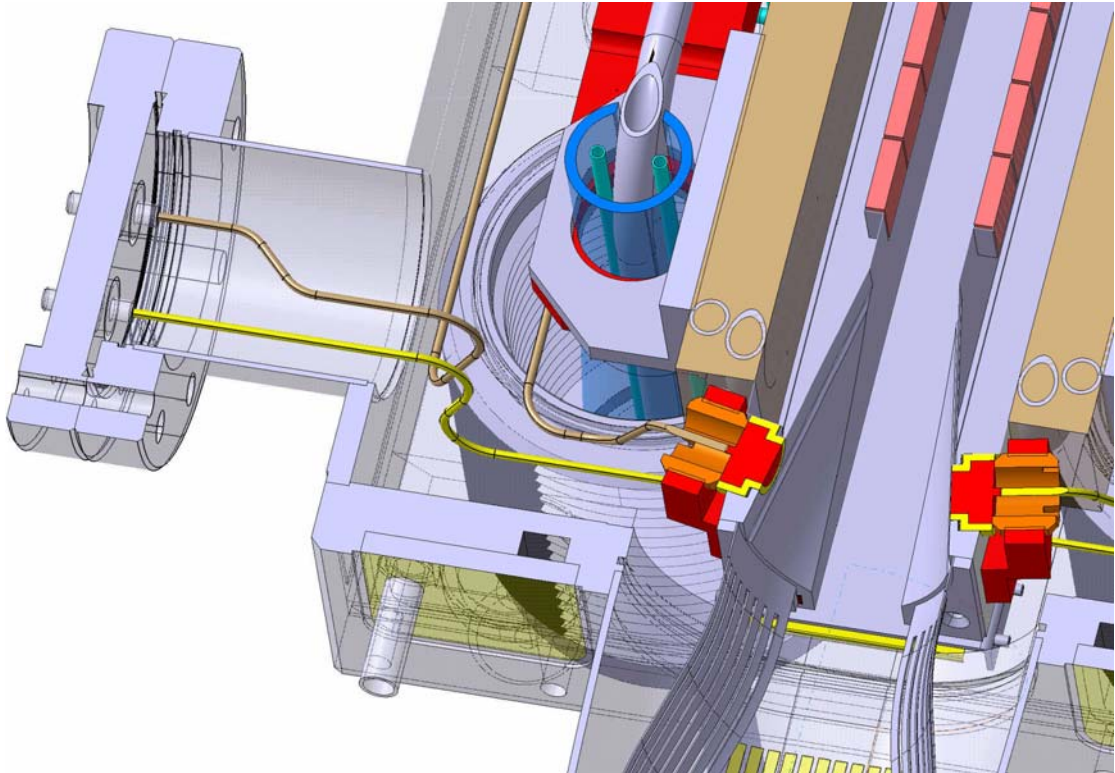


**Figure 3:** Particular of the metallic support of the jaw with holes for BPM, grooves at the middle in order to create a weak point (central regulation system).

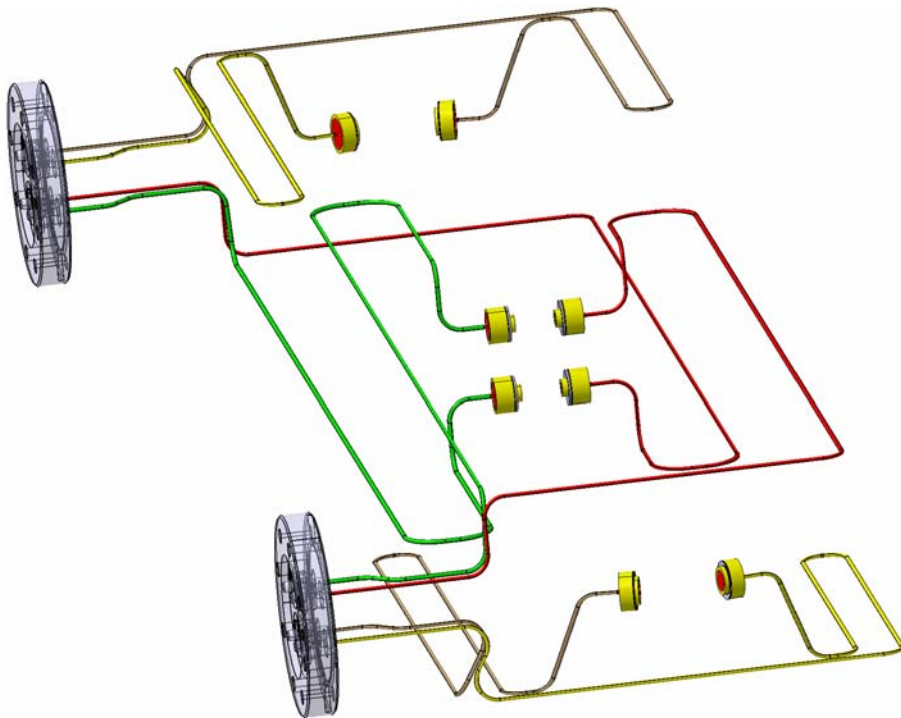


**Figure 4:** Cutaway of central regulation system with BPM buttons, cables and external flange for electrical connections.





**Figure 5:** Particular of BPM with its fine positioning system placed at the extremities of the jaw.



**Figure 6:** Layout of the BPM cables.

#### 4. Action list.

ACTION	MANAGED BY	OPENED	CLOSED
Verify potential problems relative to machining and brazing (no brazing) of Molybdenum	G. Favre	28/02/2008	closed
Verify the feasibility of the Molybdenum back stiffener (PLANSEE, PAM)	G. Arnau	24/04/2008	closed
Verify the feasibility of Molybdenum pipes (PLANSEE)	G. Arnau	24/04/2008	closed
Supply of metal-diamond composite samples for UHV tests.	L. Weber	14/03/2008	closed
Validation of the metal-diamond materials to UHV requirements.	I. Wevers W. Vollenberg	14/03/2008	closed
Purchasing of Mo plate and Mo tube for tests	G. Arnau	19/06/2008	closed
Define specifications for metal-diamond samples to be used for RF tests	F. Caspers G. Izquierdo	24/04/2008	Standby
Verify with R. Assmann the cleaning efficiency of a "comb" jaw.	A. Bertarelli A. Dallochio	27/03/2008	Standby
Tests on Mo plate and tube: machining, welding, bending dimensional stability after baking out.	G. Favre G. Arnau	19/06/2008	In progress
Identify one or more ceramics with the following properties: Resistivity :1-100 $\Omega$ m Diel. Const: as low as possible (up to 5) Loss factor: < 1E-2 Brazeability to metal support. High density	G. Arnau	19/06/2008	In progress
Once ceramic identified do brazing and machining tests	G. Arnau G. Favre	19/06/2008	Standby
Contact Plansee and ARC for limitations of large size pieces of diamond composites	G. Arnau	3/07/2008	closed
Purchase of metal-diamond samples to do brazing tests and thick coating test	G. Arnau	19/06/2008	obsolete
Mechanical calculations for: dimensioning the grooves dimension of the stud effect of gravity interest of locally doubling the rib plate	A. Bertarelli A. Dallochio	3/07/2008	In progress
Thermo-mechanical calculations using Cu-diamond and Al-diamond to confirm its interest	A. Bertarelli A. Dallochio	3/07/2008	In progress
Study the metallurgical compatibility of Materials for cooling system	G. Arnau	3/07/2008	In progress
Contact BNL for radiation tests	G. Arnau	3/07/2008	To be done
Verify with R. Assmann the collimation	A. Dallochio	17/07/2008	To be done

efficiency in case of ceramic jaws.			
Prepare a summary of design solutions.	A. Bertarelli A. Dallochio	17/07/2008	In Progress
Contact CADFEM to fix a “bug” found in ANSYS WORKBENCH	A. Dallochio A. Bertarelli	05/09/2008	To be done
Prepare a document for PLANSEE including design specifications of the back-stiffener	A. Bertarelli	05/09/2008	To be done