

# Collimator Design Meetings

## Minutes of the meeting 52 (02/12/2004)

**Present:** Aberle, Assmann, Bertarelli, Calatroni, Hänni, Kadi, Mayer, Perret, Principe (TS/CV)

**Minutes # 51:** No remarks on previous minutes

### RF CONTACT FINGER DESIGN

1. Roger reported that all the pieces are now being cleaned. According to Sergio preliminary tests could be started in two weeks, just before Christmas break. For the assembly drawing of the bench test see [RFTestBenchAssy](#).
2. As a guideline for the test conduct Manfred proposed a similar test performed on the metallized ceramic chambers. For details see [MKDTiB](#)

### NEWS FROM FINANCE DEPARTMENT / ORDERING OF COMPONENTS

1. An answer on the ordering procedure is to be given soon (Enrico was absent).

### TORQUE MEASUREMENTS ON SPS TEST MOTORS

1. Oliver informed that P. Francon is finalizing the components for the mechanical measuring tool.
2. Roberto reported that the electronic measuring device has also been ordered and has already left the factory and should be soon available.

### ELECTRONIC COMPONENTS

1. A presentation giving the status of electronic components and motorization is given by Roberto. Details can be found in [RL\\_CDM\(040212\).pdf](#)
2. According to Roberto there are only two known companies on the market producing radiation-hard motors, and one of these seems not interested to develop motors with more than 0,7Nm torque (against 2 Nm required) ...
3. Radiation dose for motors: calculations are currently being done by Vasilis to check the level of radiation in critical locations. According to first estimations, there are some location where the dose is actually more than 1 MGy/year. This would reduce the expected lifetime to 10 years if motors qualified up to 10 MGy are chosen. Could we think of changing more often the motors?
4. A discussion was held on the type of displacement sensors which are necessary and on how to calibrate them (1 week time is required for calibration in the tunnel). The strategy for the data acquisition is not yet clear (calibrated sensors or zero-position sensors + resolver or ...)
5. As a general conclusion, it was observed that a clarification of the required functional specification for the electronic equipment is highly necessary. One or more specific meetings will be held between Roberto and the Project management (Ralph + ...).
6. Temperature sensors: an improvement of the PT100 sensor positioning is necessary in order to obtain a good and permanent thermal contact with the jaw.

### AOB

1. A preliminary discussion was held with R. Principe from TS/CV to present the needs for the collimator cooling system connection to the general cooling service. Rosario has acknowledged the requirements and will study the various options (contacting Roger and Alessandro). A new update meeting will be held in a couple of weeks.
2. Active length of TCP jaws: Ralph confirmed that for all TCP in IR3, the active length has been set to 600 mm. For the IR7 a final decision has not been taken yet, but it is highly probable that it will be more than 200mm. It is decided that the official drawings will be released with a length of 600 mm (possible modification will be discussed with the supplier).
3. A dedicated meeting to study the mechanical plug-in layout with J.-P. Quesnel will be held on Dec. 3<sup>rd</sup>.

## **ACTION LIST to be followed up:**

Divisional request for motors MS	#31	Oliver, Fabrice, Stefano
Contact fingers – model for tests top and side	#34	Sergio, Roger
Play between motor spindle and jaw	#34	Roger
Non-symmetric heating of vacuum flanges	#34	Vasilis, Oliver, Miguel, Rathjen
Radiation issues – heat evacuation, air duct, space, shielding		Ralph
Detailed information on electrical plug-in and sensors ( <b>URGENT</b> )	#45	Roberto
Detailed information on water plug-in ( <b>URGENT</b> )	#45	Manfred
New Fluka simulation for 7TeV accident case	#47	Vasilis
Updated calculation on beam optics during transient	#49	Ralph
Acceptable RF design by RF people	#50	Ralph
Radiation dose on electrical components ( <b>URGENT</b> )	#50	Vasilis, Roberto
Availability of flange blanks	#51	Raymond

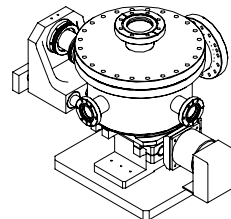
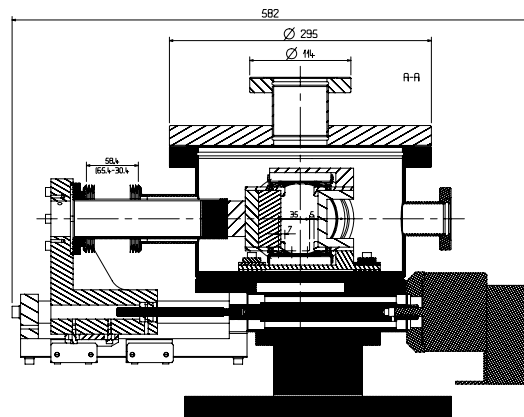
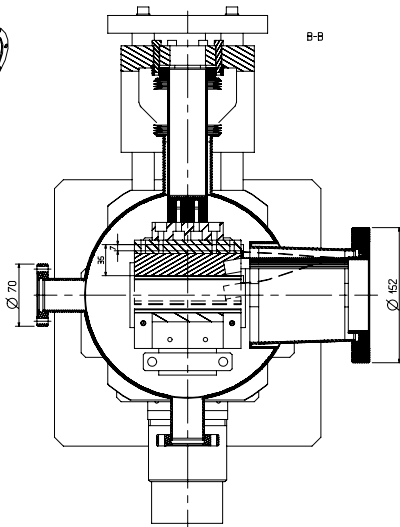
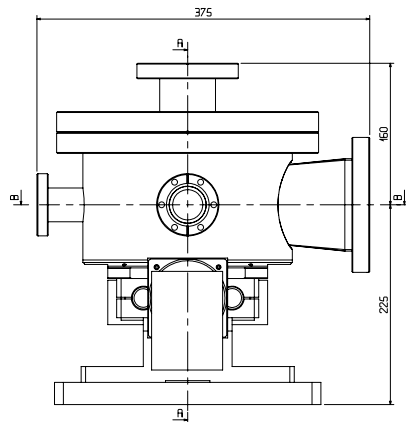
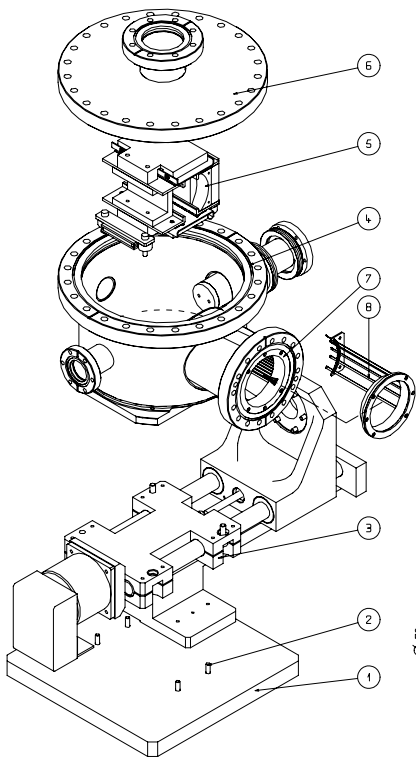

REF.	DESCRIPTION	QTY	UNIT	REVISION	DATE	BY	APP.
1	RE TEST FINGERS FOLDING PHOTO	8					
1	R.F. TEST FINGERS	7					
1	DOIGTS DE TEST R.F.	7					
1	UPPER FLANGE	6					
1	BRICE SUPERIEUR	6					
1	TEST BULBS	5					
1	BLACS DE TEST	5					
1	VASELIN VASSIL	4					
1	ENCRANTE A VIDE	4					
1	EXISTING ASS.	3					
1	MONTAGE EXISTANT	3					
4	VIS CY.TRASP.INJ	2	AA 316	M6x30x30	4.7.62.71		
1	BASE PLATE	1					
1	PLAQUE DE BASE	1					

REV.	DESCRIPTION	DATE	BY	APP.
1	Secondary Collimator for Cleaning - Prototype	1966-10-12		
2	R. F. CONTACT TEST BENCH ASS.	1966-10-12		
3	ENS. BANC DE TEST CONTACT R.F.	1966-10-12		

THIS DRAWING IS NOT VALID FOR EXECUTION. NOT VALID FOR EXECUTION. LHC/CTS-P0268

REVISIONS  
 1. 1966-10-12  
 2. 1966-10-12  
 3. 1966-10-12

IND.	DATE	NO/NAME	ZONE	MODIFICATION
16				
15				
14				
13				
12				
11				
10				
9				
8				
7				
6				
5				
4				
3				
2				
1				

# MKD Ti-metallised ceramic vacuum chamber current test

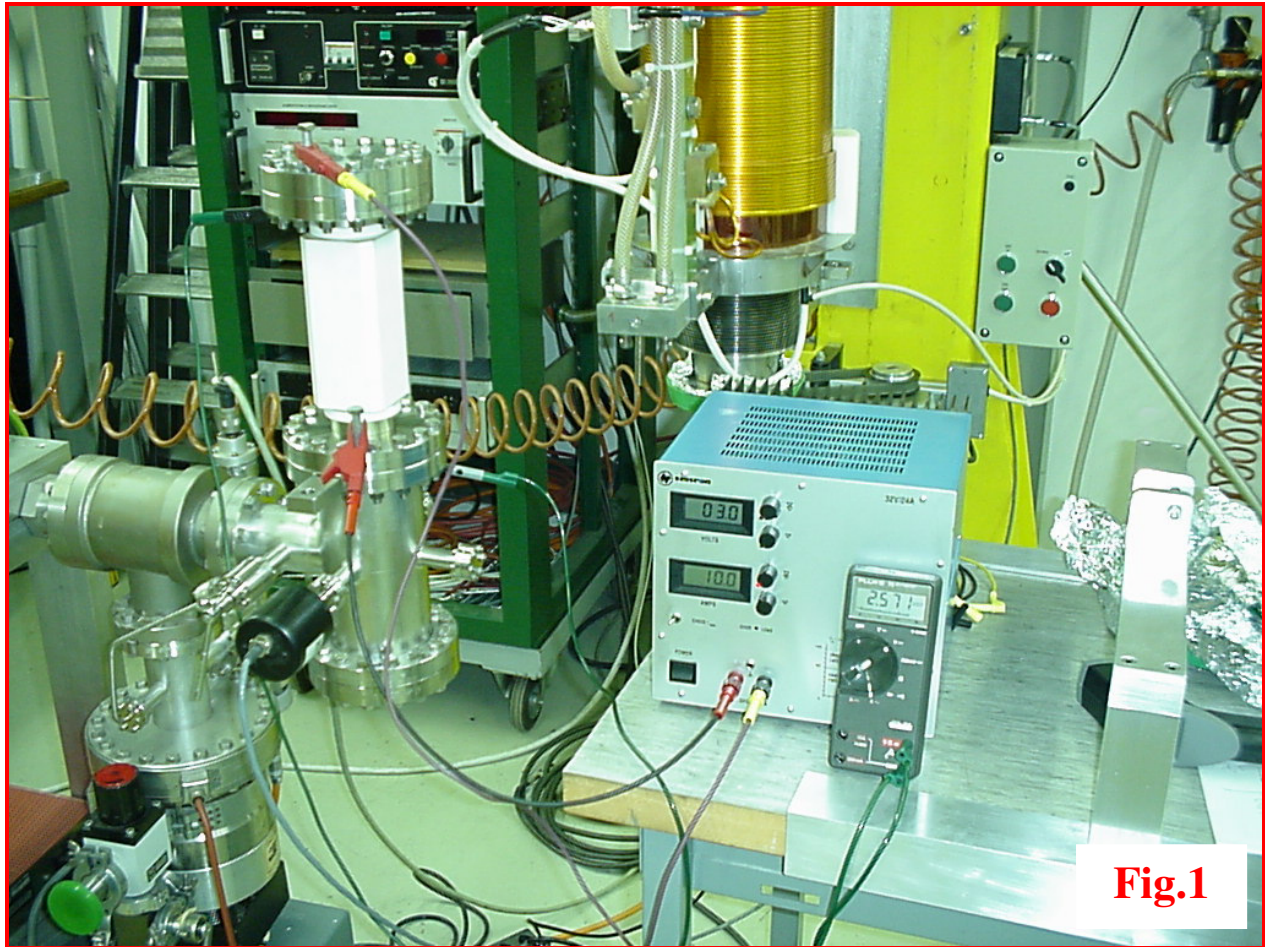

## 10A DC current test during 8 hours at vacuum of $10^{-7}$ (Fig.1):

Length of chamber: 25cm

Resistance of Ti-layer at 24.8°C:  $2.571\text{V}/10\text{A}=0.2571\ \Omega$  (start)

Resistance of Ti-layer at 34.5°C:  $2.625\text{V}/10\text{A}=0.2625\ \Omega$  (after 8 hrs)

$\Delta T=9.7^\circ\text{C}$ ,  $\Delta R=5.4\text{m}\Omega$ , temp. coefficient of Ti-layer= $0.0020958$

(Maximum bunch current is about 10A)

## 43 A pulsed current test (Fig.2) & (Fig.3):

Metallised chamber is connected in R-L-C discharge circuit (Fig.2)

The repetition rate of the discharge (Fig.3) is one second

DC resistance is measured before the test :  $0.312\ \Omega$

After 300.000 discharges with damped current oscillation of 43A amplitude\*\* with rise time of  $1\ \mu\text{s}$ , the chamber resistance is measured again :  $0.311\ \Omega$  at the same temperature

\*\*Bunch interval 25ns, 7TeV bunch length is about 1ns with 30A amplitude. Bunch repetition frequency 640 MHz with 14micron skin depth Ti. Layer thickness in chamber 4-5micron. Optical control showed no damage of Ti-layer. Maximum operational current density Ti-layer  $20\ \text{A}/\text{mm}^2$ .

# 43A pulsed current test for 300.000 pulses without vacuum

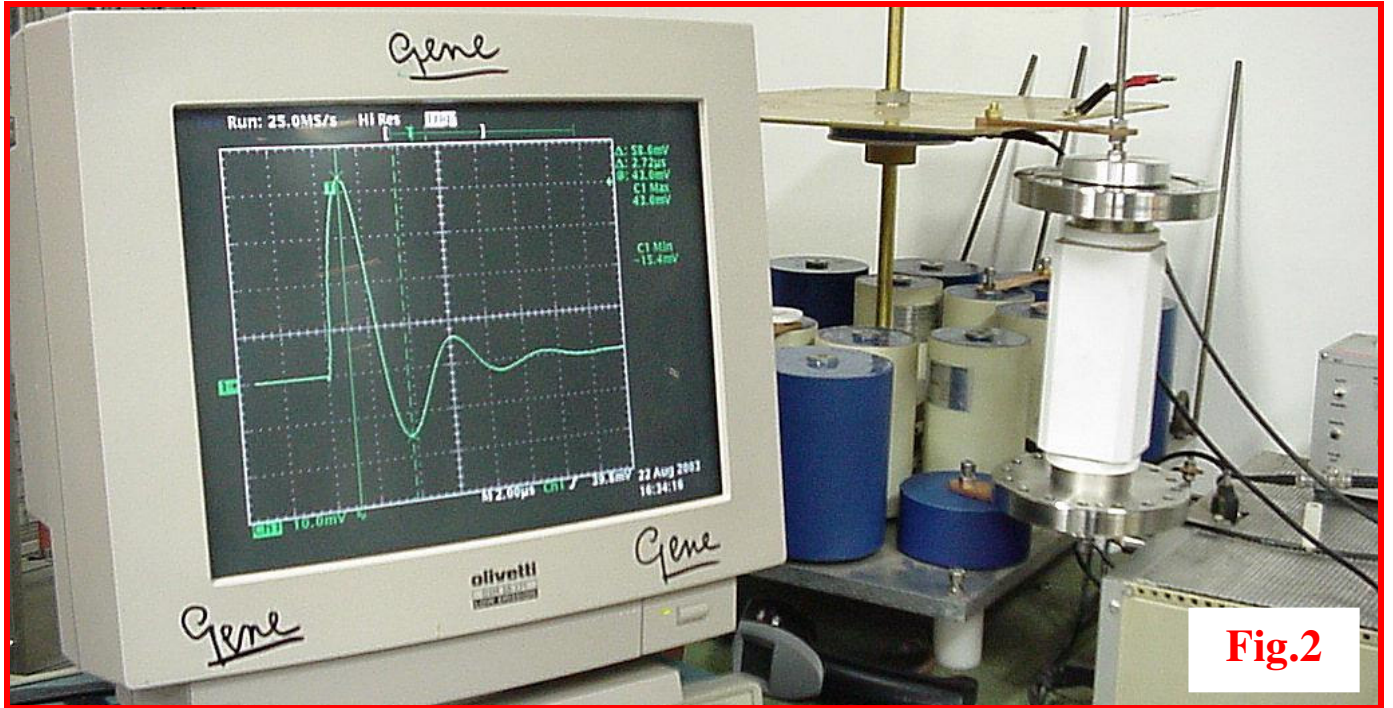

**Fig.2**

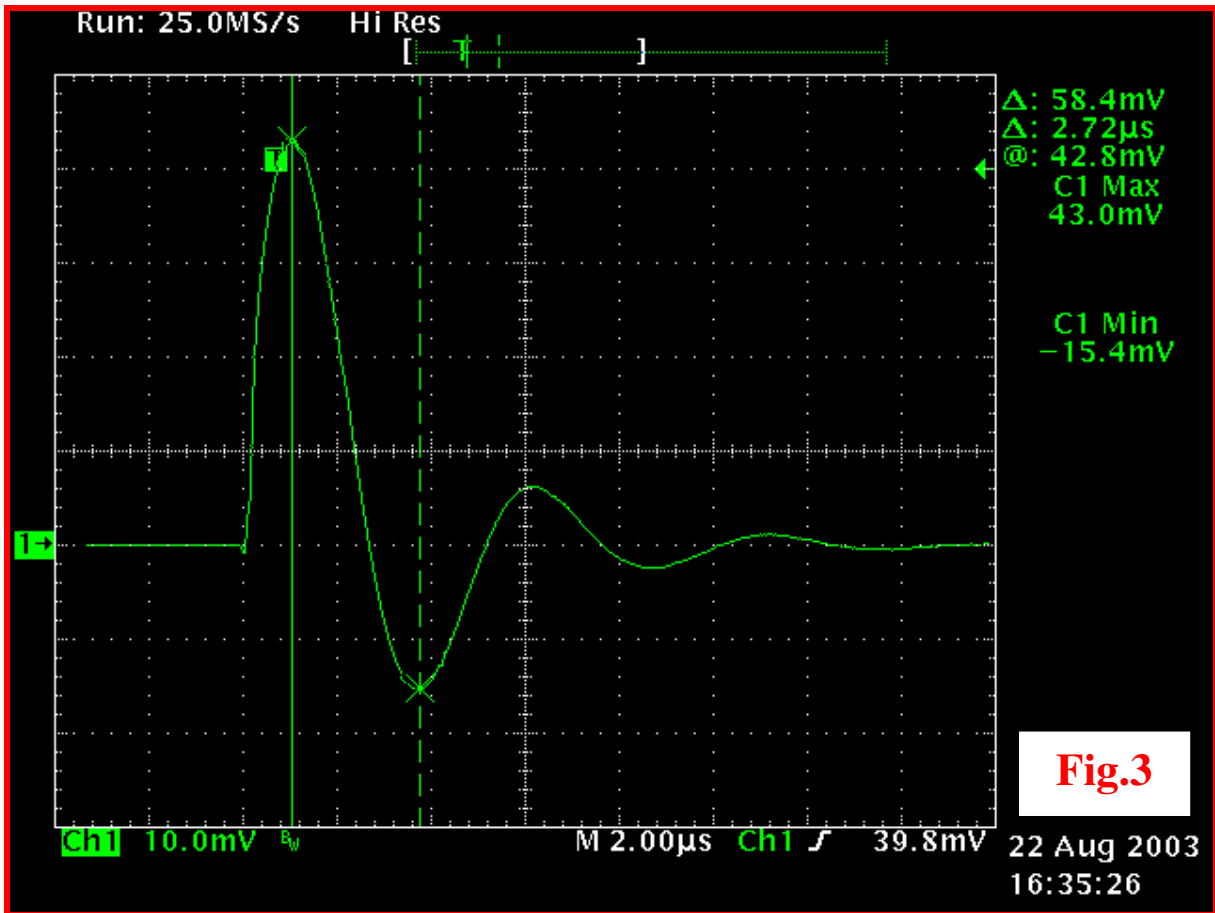

**Fig.3**

# MOTORS

- 2 companies available for Rad-hard (10 MGray) motors
  - Tectra DE: motors from AML
    - Max 0.7 Nm
    - No interest to develop a more powerful motor
  - Astrosyn International Technology
    - They claim they can do it in size NEMA 34 2 stack (?):
    - 82.5 mm square housing, 93 mm long. Maybe bigger.

# Position Sensors

- We cannot rely on microswitches for “Home Position” with a precision (repeteability) of  $\pm 10 \mu\text{m}$
- We need a precise position sensor to determine the Home position (zero)
- Then we can survive with a relative measurement (counting steps? Encoder?)

# Position Sensors

- Using this strategy, we don't need anymore any calibration, neither on surface, nor in the tunnel. Only a precise measurement at metrology of the position of Home position.
- We can in any time find the "Zero" position, and go to the right position.
- The only error is drift with time and temperature. No calibration error to be taken into account. Simplify considerably the control system.



# Position Sensors: LVDT

(Linear Variable Displacement Transducer)

- Only choice to get good precision.
- Magnetostrictive sensors have in situ electronics (not rad hard...)
- If we don't use it for position feedback, we don't need to calibrate. We save at least 2 weeks FTE.
- We need to implement a home position research. Several controllers have it as a standard procedure, but on encoders. It might be necessary to make some tricks.
- Even if there is no calibration, it should give a rough idea ( $\pm 100 \mu\text{m}$ ?) of the actual position.
- Contactless: illimited mechanical lifetime. No special problems with radiation (no parts unde mechanical stress!!! (to be checked)).

# Encoders

- LEP ok?
- PS Encoders?

# Microswitches

- Beam dumps switches seem ok up to 10 MGray. To be sent somewhere for test
- If not good up to 50 Mgray, we can buy only the mechanism, and try to do ourself the housing in ceramic
  - (CeramTec can do exotic machining. Certainly other companies exist)
  - We might have troubles with Copyright if we ask to machine at the same dimension than the ones we already use??

# Temperature sensors

- It seems that we are measuring the temperature of the metal in the PT100
- Some more work to do on design to improve mechanical stability and thermal transfer from the jaw to the sensor.
- Conditioning of any sensor is straightforward (standard technology).